

Weather Protected IP66

Hollow Shaft Option

Mounting in any plane to customer's requirements

OPTIONS

- Mounting flange/brackets to customer's requirements
- Anti-condensation heater (self regulating)
- Hollow shaft
- Stainless Steel construction
- Internal or external slew limit switch
- Internal or external azimuth encoder
- Factory fitted flying leads

OPERATING SPECIFICATION

Ambient Temperature Range	-30 °C to +60 °C
Maximum Speed	40 rpm (higher on request)
Maximum Voltage	3kV
Maximum Throughput Current	3000 Amps excluding earths and neutrals
Protection	IP66
Mounting	In any plane

TECHNICAL DETAILS

Housing Material	Mild Steel grade 43A
Shaft	Carbon Steel 080M40
Bearings	Sealed for life ball journal
Slip Rings	Phosphor bronze (precious metal plated for signals)
Brushes	Minimum of 2/ring (copper graphite for power, silver graphite for signals)
Fasteners	Stainless Steel Metric

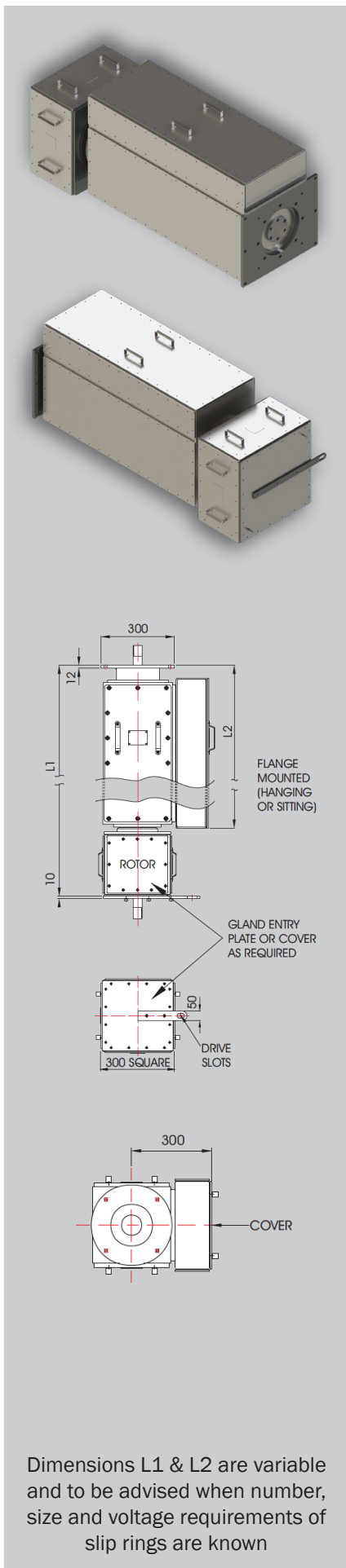

Dimensions L1 & L2 are variable and to be advised when number, size and voltage requirements of slip rings are known